



ORIENT DISPLAY

Your Total LCD Solution Provider

Specification for TFT

AFR240320A0-2.0INTM-I

Revision V1.0



A	Orient Display
FR	TFT Type
240320	Resolution 240 x 320
A0	Serial A0
2.0	2.0", Module Dimension 35.8x52.1x2.65 mm
I	IPS Display
N	Top: -20~+70°C; Tstr: -30~+80°C
T	Transmissive/Normally Black
M	Medium Brightness, 500cd/m2
/	No Touch Panel
/	Controller JD9852
I	MIPI+one data lane



Revision History

Date	Rev. No.	Page	Summary
2019.06.11	V1.0	ALL	FIRST ISSUE

Orient Display (N.A.) Ltd.
220 Royal Crest Court, Unit 06, Markham, ON, Canada L3R 9Y2
Tel: 905-477-1166 Fax: 905-477-1782

Orient Display (USA) Corp.
14925 SE Allen Road, Suite 203 B, Bellevue, WA 98006
Tel: (425)698-1938 Fax: (425)698-1852

Contents

1. Basic Information	4
1.1 Features	4
1.2 Mechanical Information	4
2. Block Diagram	5
3. Outline Dimension	6
4. Input terminal Pin Assignment	7
5. LCD Optical Characteristics	8
5.1 Optical Specification	8
5.2 Measuring Condition.....	8
5.3 Measuring Equipment.....	9
6. Electrical Characteristics	11
6.1 Absolute Operation Rating (Ta=25 VSS=0V)	11
6.2 DC Electrical Characteristics	11
6.3 LED Backlight Characteristics	12
7. AC Characteristic	14
7.1 Reset Input Timing	14
7.2 Timings for DSI Video mode.....	15
8. LCD Module Out-Going Quality Level	17
8.1 VISUAL & FUNCTION INSPECTION STANDARD	17
8.1.1 Inspection Conditions	17
8.1.2 Definition	17
8.1.3 Sampling Plan	18
8.1.4 Criteria (Visual)	19
9. Reliability Test Result	22
10. Cautions and Handling Precautions	23
10.1 Handling and Operating the Module	23
10.2 Storage and Transportation.....	23
11. Packing	24

1. Basic Information

* Description

This is a color active matrix TFT (Thin Film Transistor) LCD (liquid crystal display) that uses amorphous silicon TFT as a switching device. This module is composed of a Transmissive type TFT-LCD Panel, driver circuit, back-light unit. The resolution of a 2.0" TFT-LCD contains 240X320 pixels, and can display up to 65K/262K colors.

1.1 Features

General Information Items	Specification	Unit	Note
	Main Panel		
Display area(AA)	30.60(H)*40.80(V) (2.0inch)	mm	-
Driver element	TFT active matrix	-	-
Display colors	65K/262K	colors	-
Number of pixels	240(RGB)*320	dots	-
Pixel arrangement	RGB vertical stripe	-	-
Pixel pitch	0.1275(H)*0.1275(V)	mm	-
Viewing angle	ALL	o'clock	-
Controller IC	JD9852	-	-
LCM Interface	MIPI+one data lane	-	-
Display mode	Transmissive/Normally Black	-	-
Operating temperature	-20 ~ +70	°C	-
Storage temperature	-30 ~ +80	°C	-

1.2 Mechanical Information

Item		Min.	Typ.	Max.	Unit	Note
Module size	Horizontal(H)		35.8		mm	-
	Vertical(V)		52.1		mm	-
	Depth(D)		2.65		mm	-
Weight			11		g	-

2. Block Diagram

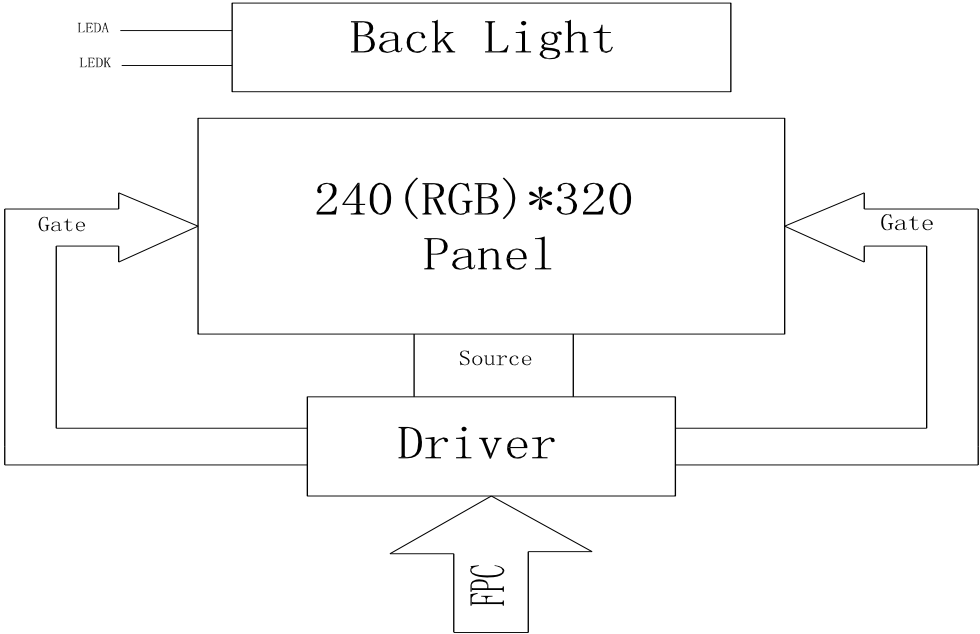

4. Input terminal Pin Assignment

Pin NO.	Symbol	Function	I/O
1	NC		
2	LEDK	Cathode pin of backlight.	P
3	NC		
4	LEDA	Anode pin of backlight.	P
5	NC		
6	VCI	Supply voltage (3.3V).	P
7	IOVCC	Power supply for I/O block(1.8-3.3V)	P
8	TE	Serve as a TE (Tearing Effect) output signal	O
9	RESET	Reset pin. Setting either pin low initializes the LSI. Must be reset after power is supplied.	I
10	GND	Ground.	P
11	NC		
12	NC		
13	GND	Ground.	P
14	MIPI_CL P	DSI Positive polarity of low voltage differential clock signal	I
15	MIPI_CL N	Negative polarity of low voltage differential clock signal	
16	GND	Ground.	P
17	MIPI_D0 P	Positive polarity of low voltage differential data signal	I
18	MIPI_D0 N	Negative polarity of low voltage differential data signal	I
19	GND	Ground.	P
20	GND	Ground.	P

5.LCD Optical Characteristics

5.1 Optical Specification

Item	Symbol	Condition	Min.	Typ.	Max.	Unit.	Note
Contrast Ratio	CR	$\Theta=0$	640	800			*
Response time	Rising	T_{R+T_F}	--	30	40	msec	*
	Falling						
Color gamut	S(%)		--	60	--	%	*
Color Filter Chromaticity	White	W_X	0.2594	0.2994	0.3394	CA310 Test	
		W_Y	0.2777	0.3177	0.3577		
	Red	R_X	0.5776	0.6176	0.6576		
		R_Y	0.3208	0.3608	0.4008		
	Green	G_X	0.2764	0.3164	0.3564		
		G_Y	0.5271	0.5671	0.6071		
	Blue	B_X	0.1072	0.1472	0.1872		
		B_Y	0.0414	0.0814	0.1214		
Viewing angle	Hor.	Θ_L	CR>10	--	80	--	*
		Θ_R		--	80	--	
	Ver.	Θ_U		--	80	--	
		Θ_D		--	80	--	
Option View Direction	ALL						

*The data comes from the LCD specification.

5.2 Measuring Condition

- Measuring surrounding : dark room
- Ambient temperature : $25\pm 2^\circ\text{C}$
- 15min. warm-up time.

5.3 Measuring Equipment

Note (1) Definition of Viewing Angle:

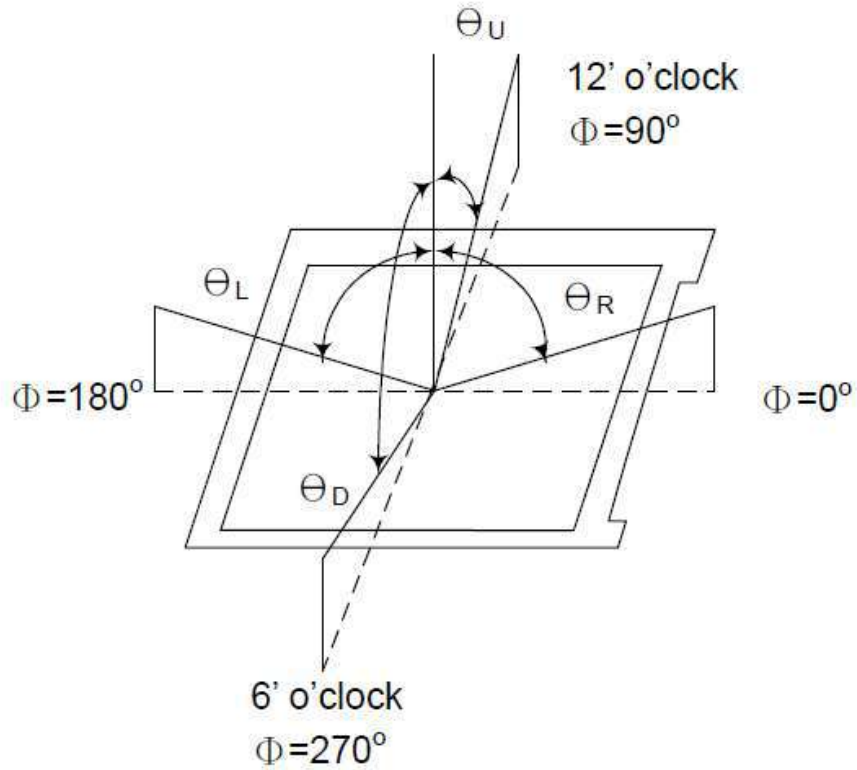

Note (2) Definition of Contrast Ratio (CR):
measured at the center point of panel

$$CR = \frac{\text{Luminance with all pixels white}}{\text{Luminance with all pixels black}}$$

Note (3) Definition of Response Time: Sum of T_R and T_F

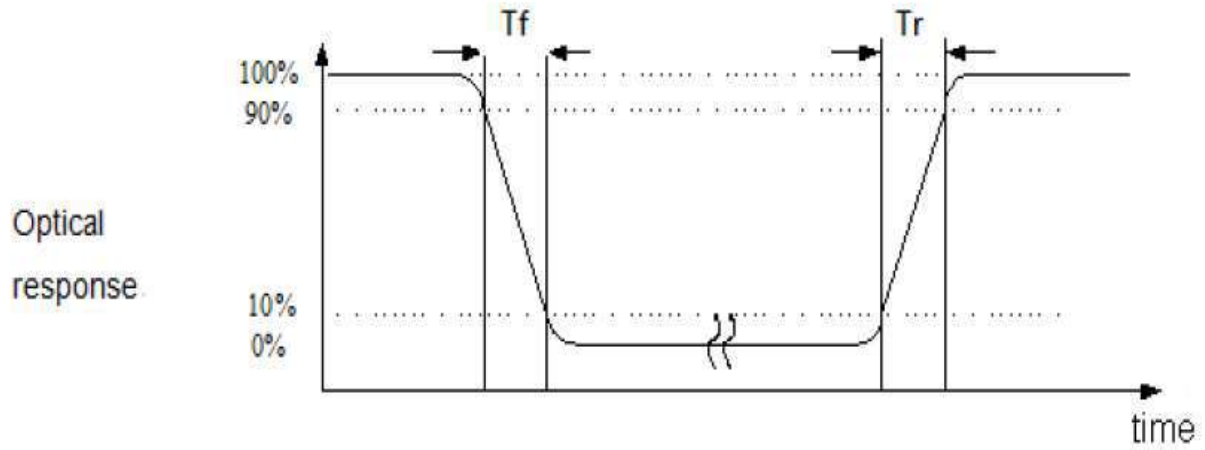

Note (4) Definition of optical measurement setup

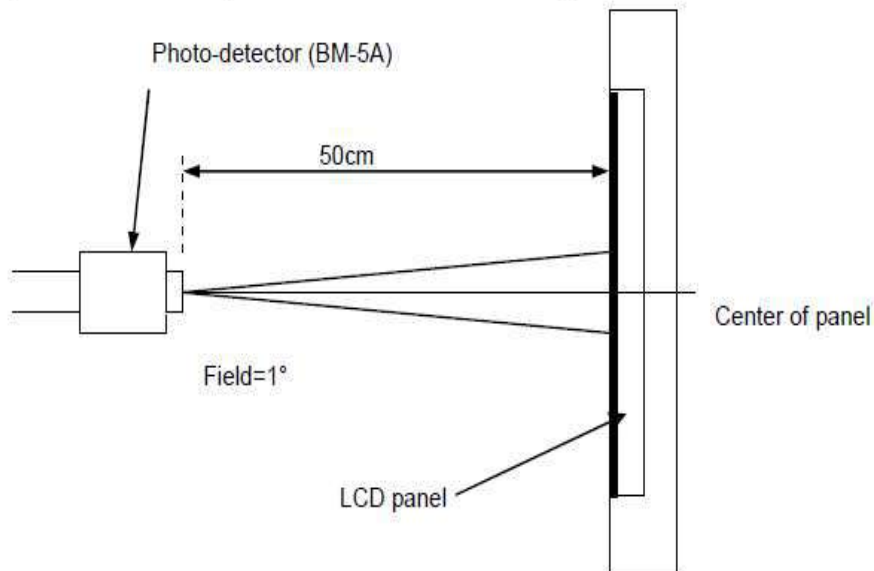

6. Electrical Characteristics

6.1 Absolute Operation Rating (Ta=25 VSS=0V)

Item	Symbol	Rating	Unit
Supply Voltage	V _{CI}	-0.3~4.6	V
Digital interface supply Voltage	IOVCC	-0.3~4.6	V
Operating temperature	T _{OP}	-20~+70	°C
Storage temperature	T _{ST}	-30~+80	°C

Note: If one of the above items is exceeded its maximum limitation momentarily, the quality of the product may be degraded.

Absolute maximum limitation, therefore, specify the values exceeding which the product may be physically damaged. Be sure to use the product within the recommend range.

6.2 DC Electrical Characteristics

Parameter	Symbol	Min.	Typ.	Max.	Unit	Note
Supply Voltage	V _{CI}	2.4	3.3	3.6	V	
Digital interface supply Voltage	IOVCC	1.65	1.8	3.3	V	
Normal mode Current consumption	I _{DD}	--	11	--	mA	
Level input voltage	V _{IH}	0.7 IOVCC		IOVCC	V	
	V _{IL}	GND		0.3 IOVCC	V	
Level output voltage	V _{OH}	0.8 IOVCC		IOVCC	V	
	V _{OL}	GND		0.2 IOVCC	V	

6.3 LED Backlight Characteristics

The back-light system is edge-lighting type with 4 chips White LED

Item	Symbol	Min.	Typ.	Max.	Unit	Note
Forward Current	I_F	15	20	--	mA	
Forward Voltage	V_F	--	12.8	--	V	
LCM Luminance	L_v	550	600	--	cd/m ²	Note3
LED life time	Hr	50000	--	--	Hour	Note1,2
Uniformity	AVg	80	--	--	%	Note3

Note (1) LED life time (Hr) can be defined as the time in which it continues to operate under the condition: $T_a=25\pm 3\text{ }^\circ\text{C}$, typical IL value indicated in the above table until the brightness becomes less than 50%.

Note (2) The "LED life time" is defined as the module brightness decrease to 50% original brightness at $T_a=25\text{ }^\circ\text{C}$ and $I_L=20\text{mA}$. The LED lifetime could be decreased if operating I_L is larger than 20mA. The constant current driving method is suggested.

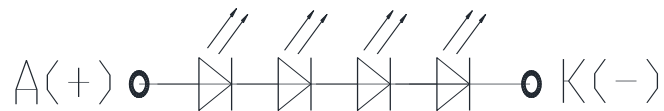

BLU CIRCUIT DIAGRAM

NOTE 3 : Luminance Uniformity of these 9 points is defined as below:

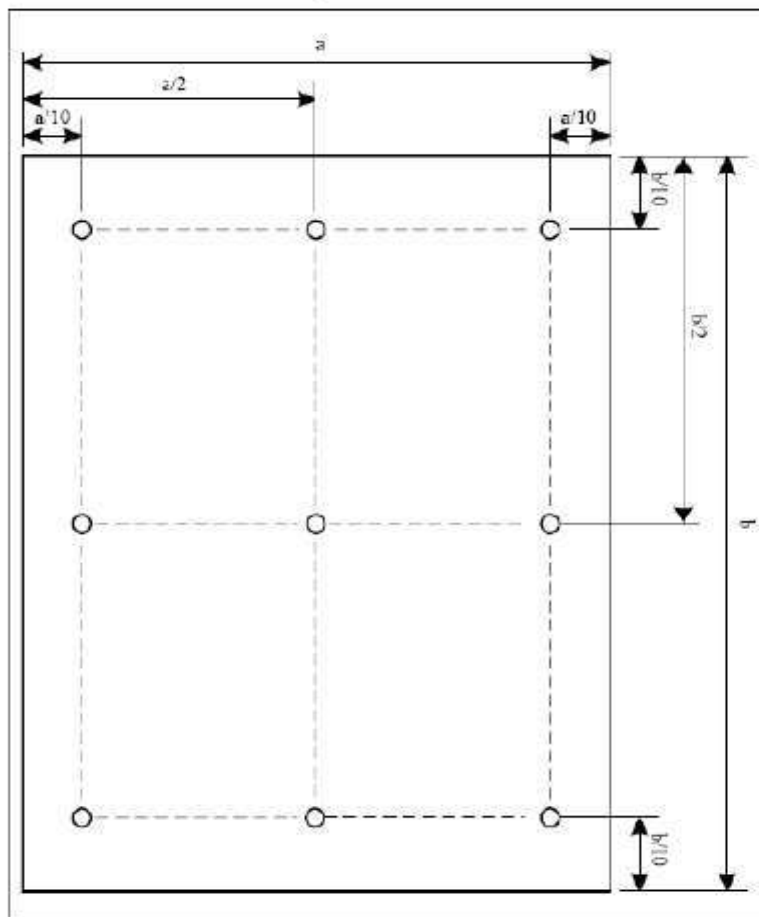

$$\text{Uniformity} = \frac{\text{minimum luminance in 9 points (1-9)}}{\text{maximum luminance in 9 points (1-9)}}$$

$$\text{Luminance} = \frac{\text{Total Luminance of 9 points}}{9}$$

7.AC Characteristic

7.1 Reset Input Timing

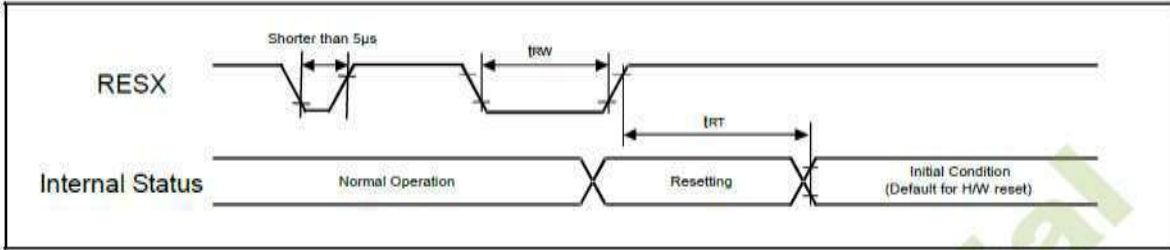

* Reset input timings

Symbol	Parameter	Related pins	Min.	Max.	Unit
t_{RW}	Reset pulse width ⁽²⁾	RESX	10	-	μs
t_{RT}	Reset complete time ⁽³⁾	-	-	5 (Note 5)	ms
		-	-	120 (Note 6, 7)	ms

- Note:** (1) The reset complete time also required time for loading ID bytes from OTP to registers. This loading is done every time when there is HW reset cancel time (t_{RT}) within 5 ms after a rising edge of RESX.
 (2) Spike due to an electrostatic discharge on RESX line does not cause irregular system reset according to the table below.

RESX Pulse	Action
Shorter than 5 μs	Reset Rejected
Longer than 10 μs	Reset
Between 5 μs and 10 μs	Reset Start

- (3) During the resetting period, the display will be blanked (The display is entering blanking sequence, which maximum time is 120 ms, when Reset Starts in Sleep Out –mode. The display remains the blank state in Sleep In –mode) and then returns to Default condition for H/W reset.
 (4) Spike Rejection also applies during a valid reset pulse as shown below:

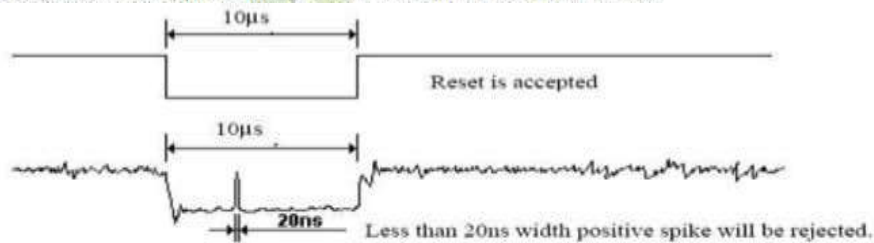

- (5) When Reset is applied during Sleep In Mode.
 (6) When Reset is applied during Sleep Out Mode.
 (7) It is necessary to wait 5msec after releasing RESX before sending commands. Also Sleep Out command cannot be sent for 120msec.

7.2 Timings for DSI Video mode

Vertical Timings

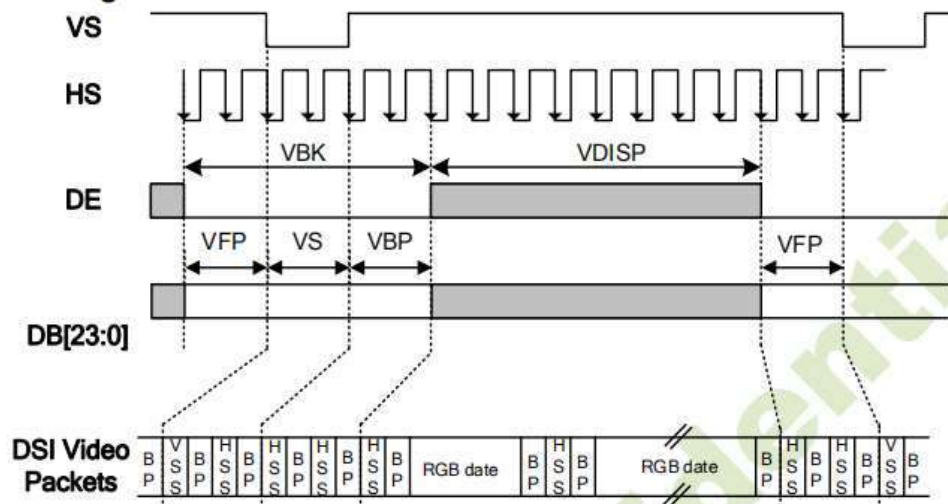

Vertical Timings for DSI Video mode I/F

Resolution=240x320 (TA=25°C, IOVCC=1.8V, VCI=2.8V)

Item	Symbol	Condition	Min.	Typ.	Max.	Unit
Vertical low pulse width	VS	-	2	-	Note(1)	Line
Vertical front porch	VFP	-	2	-	-	Line
Vertical back porch	VBP	-	2	-	Note(1)	Line
Vertical blanking period	VBK	VS+VBP+VFP	6	-	-	Line
Vertical active area	-	VDISP	-	320	-	Line
Vertical Refresh rate	VRR	-	-	60	-	Hz

Vertical Timings for DSI Video mode I/F

Horizontal Timings

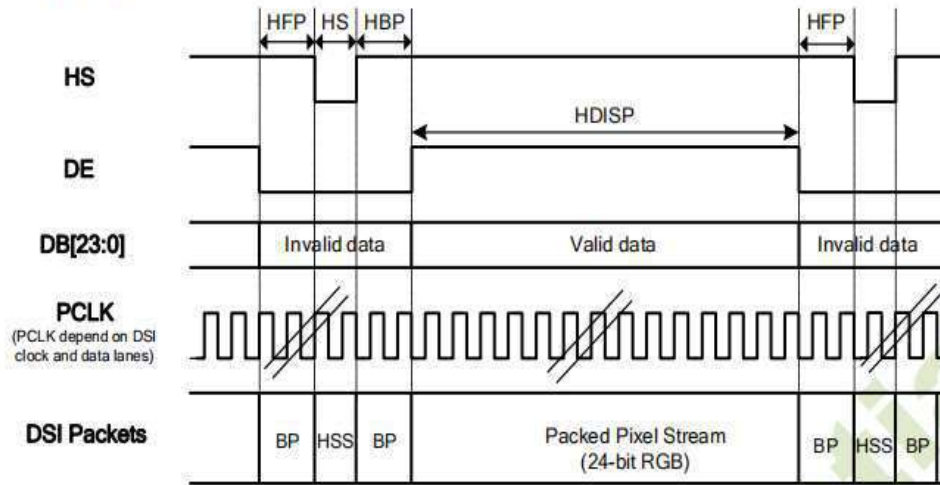

Horizontal Timing for DSI Video mode I/F

Resolution=240x320 (TA=25°C, IOVCC=1.8V, VCI=2.8V)

Item	Symbol	Condition	Min.	Typ.	Max.	Unit
HS low pulse width	HS	-	6	-	78	DCK
Horizontal back porch	HBP	-	5	-	78	DCK
Horizontal front porch	HFP	-	5	-	78	DCK
Horizontal blanking period	HBLK	HS+HBP+HFP	16	-	88	DCK
Horizontal active area	HDISP	-	-	240	-	DCK

Note: (1) HS+HBP>0.5uS.

(2) HFP>0.5uS.

Horizontal Timings for DSI Video mode I/F

8.LCD Module Out-Going Quality Level

8.1 VISUAL & FUNCTION INSPECTION STANDARD

8.1.1 Inspection Conditions

Inspection performed under the following conditions is recommended.

Temperature : $25\pm 5^{\circ}\text{C}$

Humidity : $65\%\pm 10\%\text{RH}$

Viewing Angle : Normal viewing Angle.

Illumination: Single fluorescent lamp (300 to 700Lux)

Viewing distance:30-50cm

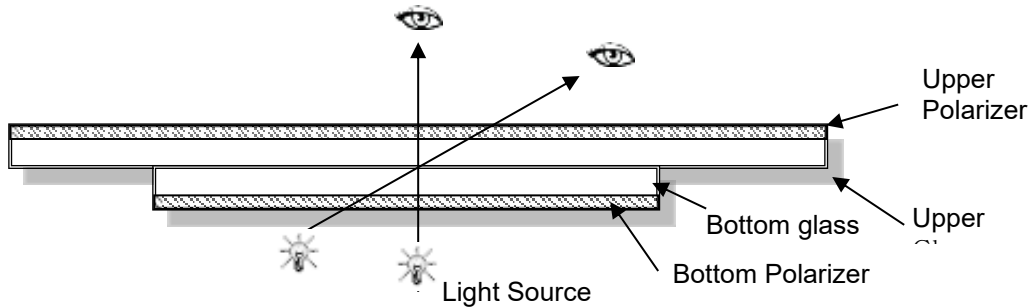

8.1.2 Definition

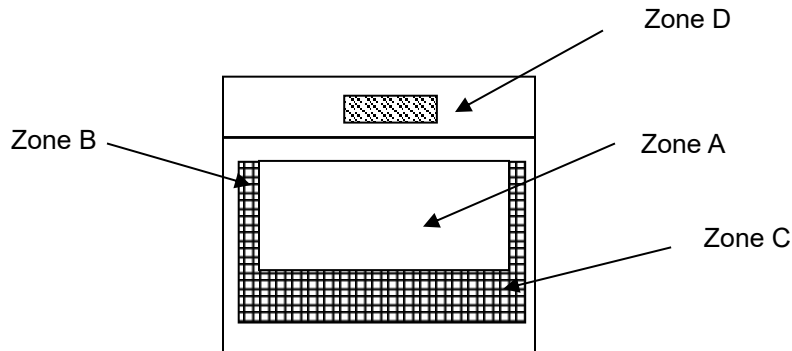

Zone A : Effective Viewing Area(Character or Digit can be seen)

Zone B : Viewing Area except Zone A

Zone C : Outside (Zone A+Zone B) which can not be seen after assembly by customer .)

Zone D : IC Bonding Area

Note:

As a general rule ,visual defects in Zone C can be ignored when it doesn't effect product function or appearance after assembly by customer

8.1.3 Sampling Plan

According to GB/T 2828-2003 ; , normal inspection, Class II
AQL:

Major defect	Minor defect
0.65	1.5

LCD: Liquid Crystal Display , TP: Touch Panel , LCM: Liquid Crystal Module

No	Items to be inspected	Criteria	Classification of defects
1	Functional defects	1) No display, Open or miss line 2) Display abnormally, Short 3) Backlight no lighting, abnormal lighting. 4) TP no function	Major
2	Missing	Missing component	
3	Outline dimension	Overall outline dimension beyond the drawing is not allowed	
4	Color tone	Color unevenness, refer to limited sample	Minor
5	Spot Line defect	Light dot, Dim spot, Polarizer Bubble ; Polarizer accidented spot.	
6	Soldering appearance	Good soldering , Peeling off is not allowed.	
7	LCD/Polarizer/TP	Black/White spot/line, scratch, crack, etc.	

8.1.4 Criteria (Visual)

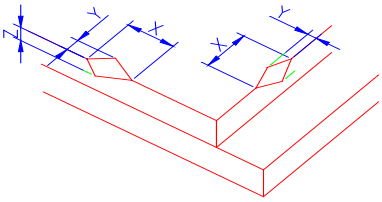
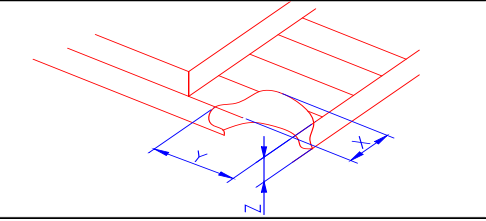
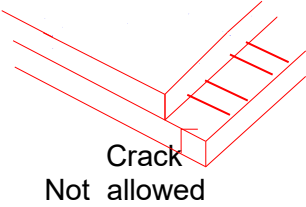
Number	Items	Criteria(mm)						
1.0 LCD Crack/Broken NOTE: X: Length Y: Width Z: Height L: Length of ITO, T: Height of LCD	(1) The edge of LCD broken	 <table border="1" data-bbox="740 569 1367 720"> <thead> <tr> <th>X</th> <th>Y</th> <th>Z</th> </tr> </thead> <tbody> <tr> <td>≤3.0mm</td> <td><Inner border line of the seal</td> <td>≤T</td> </tr> </tbody> </table>	X	Y	Z	≤3.0mm	<Inner border line of the seal	≤T
	X	Y	Z					
	≤3.0mm	<Inner border line of the seal	≤T					
(2)LCD corner broken	 <table border="1" data-bbox="786 1031 1321 1123"> <thead> <tr> <th>X</th> <th>Y</th> <th>Z</th> </tr> </thead> <tbody> <tr> <td>≤3.0mm</td> <td>≤L</td> <td>≤T</td> </tr> </tbody> </table>	X	Y	Z	≤3.0mm	≤L	≤T	
X	Y	Z						
≤3.0mm	≤L	≤T						
(3) LCD crack	 <p style="text-align: center;">Crack Not allowed</p>							

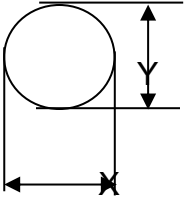
2.0	<p>Spot defect</p>  <p>$\Phi=(X+Y)/2$</p>	① light dot (LCD/TP/Polarizer black/white spot , light dot, pinhole, dent, stain)																							
		<table border="1"> <thead> <tr> <th rowspan="2">Zone Size (mm)</th> <th colspan="3">Acceptable Qty</th> </tr> <tr> <th>A</th> <th>B</th> <th>C</th> </tr> </thead> <tbody> <tr> <td>$\Phi \leq 0.10$</td> <td colspan="3">Ignore</td> </tr> <tr> <td>$0.10 < \Phi \leq 0.20$</td> <td colspan="3">3(distance $\geq 10\text{mm}$)</td> </tr> <tr> <td>$0.20 < \Phi \leq 0.25$</td> <td colspan="3">2</td> </tr> <tr> <td>$\Phi > 0.3$</td> <td colspan="3">0</td> </tr> </tbody> </table>	Zone Size (mm)	Acceptable Qty			A	B	C	$\Phi \leq 0.10$	Ignore			$0.10 < \Phi \leq 0.20$	3(distance $\geq 10\text{mm}$)			$0.20 < \Phi \leq 0.25$	2			$\Phi > 0.3$	0		
		Zone Size (mm)		Acceptable Qty																					
			A	B	C																				
		$\Phi \leq 0.10$	Ignore																						
$0.10 < \Phi \leq 0.20$	3(distance $\geq 10\text{mm}$)																								
$0.20 < \Phi \leq 0.25$	2																								
$\Phi > 0.3$	0																								
② Dim spot (LCD/TP/Polarizer dim dot, light leakage, dark spot)																									
<table border="1"> <thead> <tr> <th rowspan="2">Zone Size (mm)</th> <th colspan="3">Acceptable Qty</th> </tr> <tr> <th>A</th> <th>B</th> <th>C</th> </tr> </thead> <tbody> <tr> <td>$\Phi \leq 0.1$</td> <td colspan="3">Ignore</td> </tr> <tr> <td>$0.10 < \Phi \leq 0.20$</td> <td colspan="3">3(distance $\geq 10\text{mm}$)</td> </tr> <tr> <td>$0.20 < \Phi \leq 0.25$</td> <td colspan="3">2</td> </tr> <tr> <td>$\Phi > 0.3$</td> <td colspan="3">0</td> </tr> </tbody> </table>	Zone Size (mm)	Acceptable Qty			A	B	C	$\Phi \leq 0.1$	Ignore			$0.10 < \Phi \leq 0.20$	3(distance $\geq 10\text{mm}$)			$0.20 < \Phi \leq 0.25$	2			$\Phi > 0.3$	0				
Zone Size (mm)		Acceptable Qty																							
	A	B	C																						
$\Phi \leq 0.1$	Ignore																								
$0.10 < \Phi \leq 0.20$	3(distance $\geq 10\text{mm}$)																								
$0.20 < \Phi \leq 0.25$	2																								
$\Phi > 0.3$	0																								
③ Polarizer accidented spot																									
<table border="1"> <thead> <tr> <th rowspan="2">Zone Size (mm)</th> <th colspan="3">Acceptable Qty</th> </tr> <tr> <th>A</th> <th>B</th> <th>C</th> </tr> </thead> <tbody> <tr> <td>$\Phi \leq 0.2$</td> <td colspan="3">Ignore</td> </tr> <tr> <td>$0.3 < \Phi \leq 0.5$</td> <td colspan="3">2(distance $\geq 10\text{mm}$)</td> </tr> <tr> <td>$\Phi > 0.5$</td> <td colspan="3">0</td> </tr> </tbody> </table>	Zone Size (mm)	Acceptable Qty			A	B	C	$\Phi \leq 0.2$	Ignore			$0.3 < \Phi \leq 0.5$	2(distance $\geq 10\text{mm}$)			$\Phi > 0.5$	0								
Zone Size (mm)		Acceptable Qty																							
	A	B	C																						
$\Phi \leq 0.2$	Ignore																								
$0.3 < \Phi \leq 0.5$	2(distance $\geq 10\text{mm}$)																								
$\Phi > 0.5$	0																								
④ Pixel bad points (light dot, Dim dot, color dot)																									
<table border="1"> <thead> <tr> <th rowspan="2">Zone Size (mm)</th> <th colspan="3">Acceptable Qty</th> </tr> <tr> <th>A</th> <th>B</th> <th>C</th> </tr> </thead> <tbody> <tr> <td>$\Phi \leq 0.1$</td> <td colspan="3">Ignore</td> </tr> <tr> <td>$0.15 < \Phi \leq 0.2$</td> <td colspan="3">2(distance $\geq 10\text{mm}$)</td> </tr> <tr> <td>$\Phi > 0.2$</td> <td colspan="3">0</td> </tr> </tbody> </table>	Zone Size (mm)	Acceptable Qty			A	B	C	$\Phi \leq 0.1$	Ignore			$0.15 < \Phi \leq 0.2$	2(distance $\geq 10\text{mm}$)			$\Phi > 0.2$	0								
Zone Size (mm)		Acceptable Qty																							
	A	B	C																						
$\Phi \leq 0.1$	Ignore																								
$0.15 < \Phi \leq 0.2$	2(distance $\geq 10\text{mm}$)																								
$\Phi > 0.2$	0																								
⑤ Polarizer Bubble																									
<table border="1"> <thead> <tr> <th rowspan="2">Zone Size (mm)</th> <th colspan="3">Acceptable Qty</th> </tr> <tr> <th>A</th> <th>B</th> <th>C</th> </tr> </thead> <tbody> <tr> <td>$\Phi \leq 0.2$</td> <td colspan="3">Ignore</td> </tr> <tr> <td>$0.3 < \Phi \leq 0.4$</td> <td colspan="3">3(distance $\geq 10\text{mm}$)</td> </tr> <tr> <td>$0.4 < \Phi \leq 0.5$</td> <td colspan="3">2</td> </tr> <tr> <td>$\Phi > 0.5$</td> <td colspan="3">0</td> </tr> </tbody> </table>	Zone Size (mm)	Acceptable Qty			A	B	C	$\Phi \leq 0.2$	Ignore			$0.3 < \Phi \leq 0.4$	3(distance $\geq 10\text{mm}$)			$0.4 < \Phi \leq 0.5$	2			$\Phi > 0.5$	0				
Zone Size (mm)		Acceptable Qty																							
	A	B	C																						
$\Phi \leq 0.2$	Ignore																								
$0.3 < \Phi \leq 0.4$	3(distance $\geq 10\text{mm}$)																								
$0.4 < \Phi \leq 0.5$	2																								
$\Phi > 0.5$	0																								

3.0	Line defect (LCD/TP /Polarizer backlight black/white line, scratch, stain)	Width(mm)	Length(mm)	Acceptable Qty		
				A	B	C
		$\Phi \leq 0.03$	Ignore	Ignore		Ignore
		$0.03 < W \leq 0.04$	$L \leq 3.0$	$N \leq 2$		
		$0.04 < W \leq 0.05$	$L \leq 2.0$	$N \leq 1$		
$0.05 < W$	Define as spot defect					
4.0	Electronic Components SMT	Not allow missing parts, solderless connection, cold solder joint, mismatch, The positive and negative polarity opposite				
5.0	Display color & Brightness	1. Color: Measuring the color coordinates, The measurement standard according to the datasheet or samples. 2. Brightness: Measuring the brightness of White screen, The measurement standard according to the datasheet or Samples.				
6.0	LCD Mura	By 5% ND filter invisible.				

Criteria (functional items)

Number	Items	Criteria (mm)
1	No display	Not allowed
2	Missing segment	Not allowed
3	Short	Not allowed
4	Backlight no lighting	Not allowed

9. Reliability Test Result

Item	Condition	Inspection after test
High Temperature Operating	70 °C, 96H	Inspection after 2~4hours storage at room temperature, the sample shall be free from defects: 1. Air bubble in the LCD; 2. Non-display; 3. Missing segments/line; 4. Glass crack; 5. Current IDD is twice higher than initial value.
Low Temperature Operating	-20 °C, 96HR	
High Temperature Storage	80 °C, 96HR	
Low Temperature Storage	-30 °C, 96HR	
High Temperature & High Humidity Storage	+60 °C, 90% RH, 96 hours.	
Thermal Shock (Non-operation)	-30 °C, 30 min ↔ 80 °C, 30 min, Change time: 5min 20CYC.	
ESD test	C=150pF, R=330, 5points/panel Air: ±8KV, 5times; Contact: ±6KV, 5 times; (Environment: 15 °C ~35 °C, 30%~60%).	
Vibration (Non-operation)	Frequency range: 10~55Hz, Stroke: 1.5mm Sweep: 10Hz~55Hz~10Hz 2 hours for each direction of X.Y.Z. (6 hours for total) (Package condition).	
Box Drop Test	1 Corner 3 Edges 6 faces, 80cm (MEDIUM BOX)	

Remark:

1. The test samples should be applied to only one test item.
2. Sample size for each test item is 5~10pcs.
3. For Damp Proof Test, Pure water (Resistance > 10MΩ) should be used.
4. In case of malfunction defect caused by ESD damage, if it would be recovered to normal state after resetting, it would be judged as a good part.
5. Failure Judgment Criterion: Basic Specification, Electrical Characteristic, Mechanical Characteristic, Optical Characteristic.

10. Cautions and Handling Precautions

10.1 Handling and Operating the Module

- (1) When the module is assembled, it should be attached to the system firmly.
Do not warp or twist the module during assembly work.
- (2) Protect the module from physical shock or any force. In addition to damage, this may cause improper operation or damage to the module and back-light unit.
- (3) Note that polarizer is very fragile and could be easily damaged. Do not press or scratch the surface.
- (4) Do not allow drops of water or chemicals to remain on the display surface.
If you have the droplets for a long time, staining and discoloration may occur.
- (5) If the surface of the polarizer is dirty, clean it using some absorbent cotton or soft cloth.
- (6) The desirable cleaners are water, IPA (Isopropyl Alcohol) or Hexane.
Do not use ketene type materials (ex. Acetone), Ethyl alcohol, Toluene, Ethyl acid or Methyl chloride.
It might permanent damage to the polarizer due to chemical reaction.
- (7) If the liquid crystal material leaks from the panel, it should be kept away from the eyes or mouth.
In case of contact with hands, legs, or clothes, it must be washed away thoroughly with soap.
- (8) Protect the module from static; it may cause damage to the CMOS ICs.
- (9) Use finger-stalls with soft gloves in order to keep display clean during the incoming inspection and assembly process.
- (10) Do not disassemble the module.
- (11) Protection film for polarizer on the module shall be slowly peeled off just before use so that the electrostatic charge can be minimized.
- (12) Pins of I/F connector shall not be touched directly with bare hands.
- (13) Do not connect, disconnect the module in the "Power ON" condition.
- (14) Power supply should always be turned on/off by the item 6.1 Power On Sequence & 6.2 Power Off Sequence

10.2 Storage and Transportation.

- (1) Do not leave the panel in high temperature, and high humidity for a long time.
It is highly recommended to store the module with temperature from 0 to 35 °C and relative humidity of less than 70%
- (2) Do not store the TFT-LCD module in direct sunlight.
- (3) The module shall be stored in a dark place. When storing the modules for a long time, be sure to adopt effective measures for protecting the modules from strong ultraviolet radiation, sunlight, or fluorescent light.
- (4) It is recommended that the modules should be stored under a condition where no condensation is allowed. Formation of dewdrops may cause an abnormal operation or a failure of the module.
In particular, the greatest possible care should be taken to prevent any module from being operated where condensation has occurred inside.
- (5) This panel has its circuitry FPC on the bottom side and should be handled carefully in order not to be stressed.

11. Packing

